



PANAGON
systems

HYDRAULIC PUMP MANUFACTURING

MFE PISTON MOTOR MODELS **BUILT BY US**

MFE 15
MFE 19



PARTS INFORMATION GUIDE

WWW.PANAGONSYSTEMS.COM



Founded nearly 35 years ago, Panagon Systems has remained a trusted company producing hydraulic parts on demand for a number of shops, manufacturers and industries. The company, located in Macomb, Michigan, is a hydraulic piston pumps and parts manufacturer, providing a vast variety of current and obsolete components. With a variety of CNC machines, Panagon produces finished product from raw materials. Which are then assembled, tested, painted and shipped from our facility. Panagon Systems attempts to fill the void OEM's create by manufacturing the phased out, expensive, unavailable pumps, motors and transmissions.

Model 15/19 2
Parts Identification 3
Parts Lists 4
Identification of Model Code 6

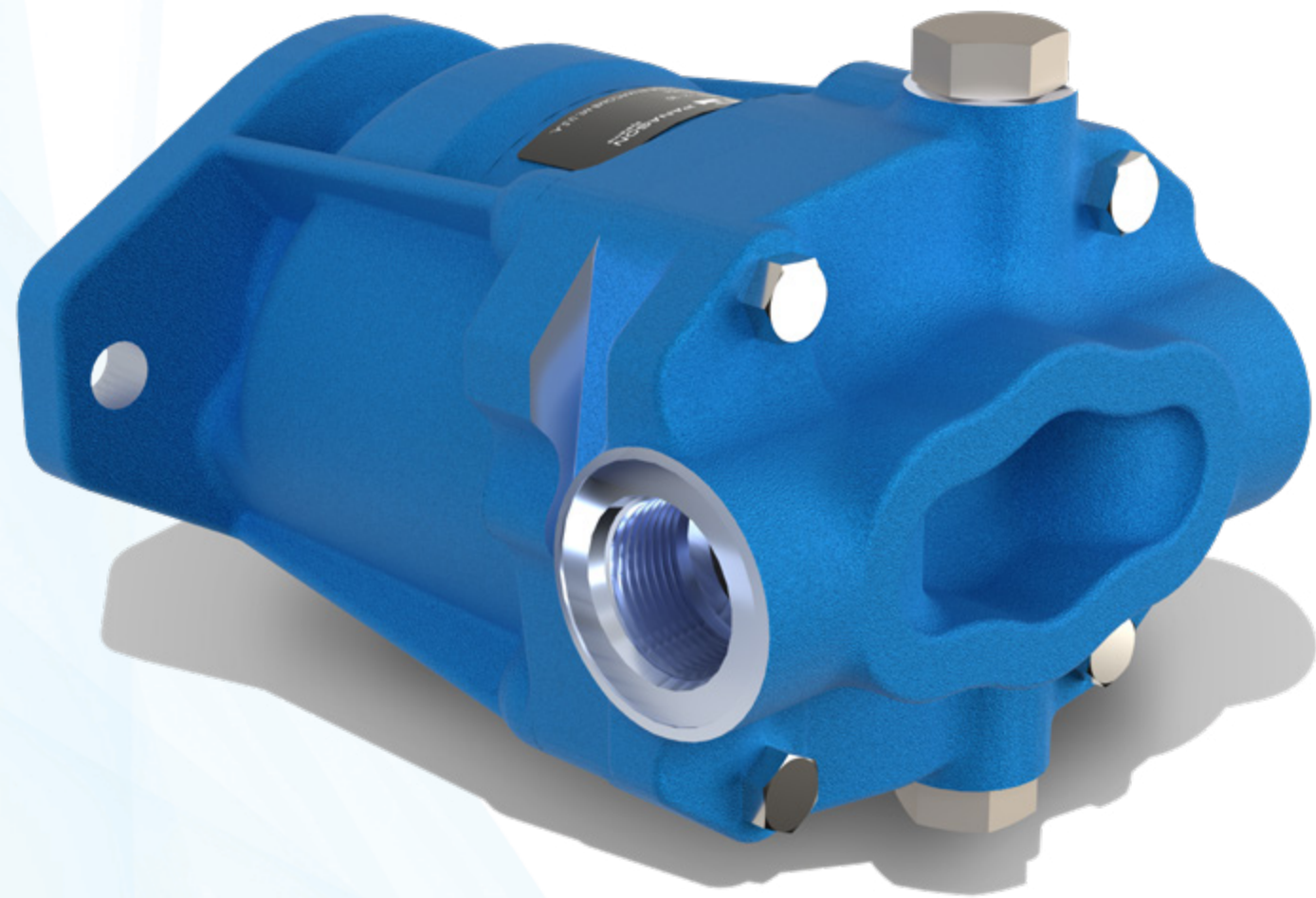

Model MFE15/19

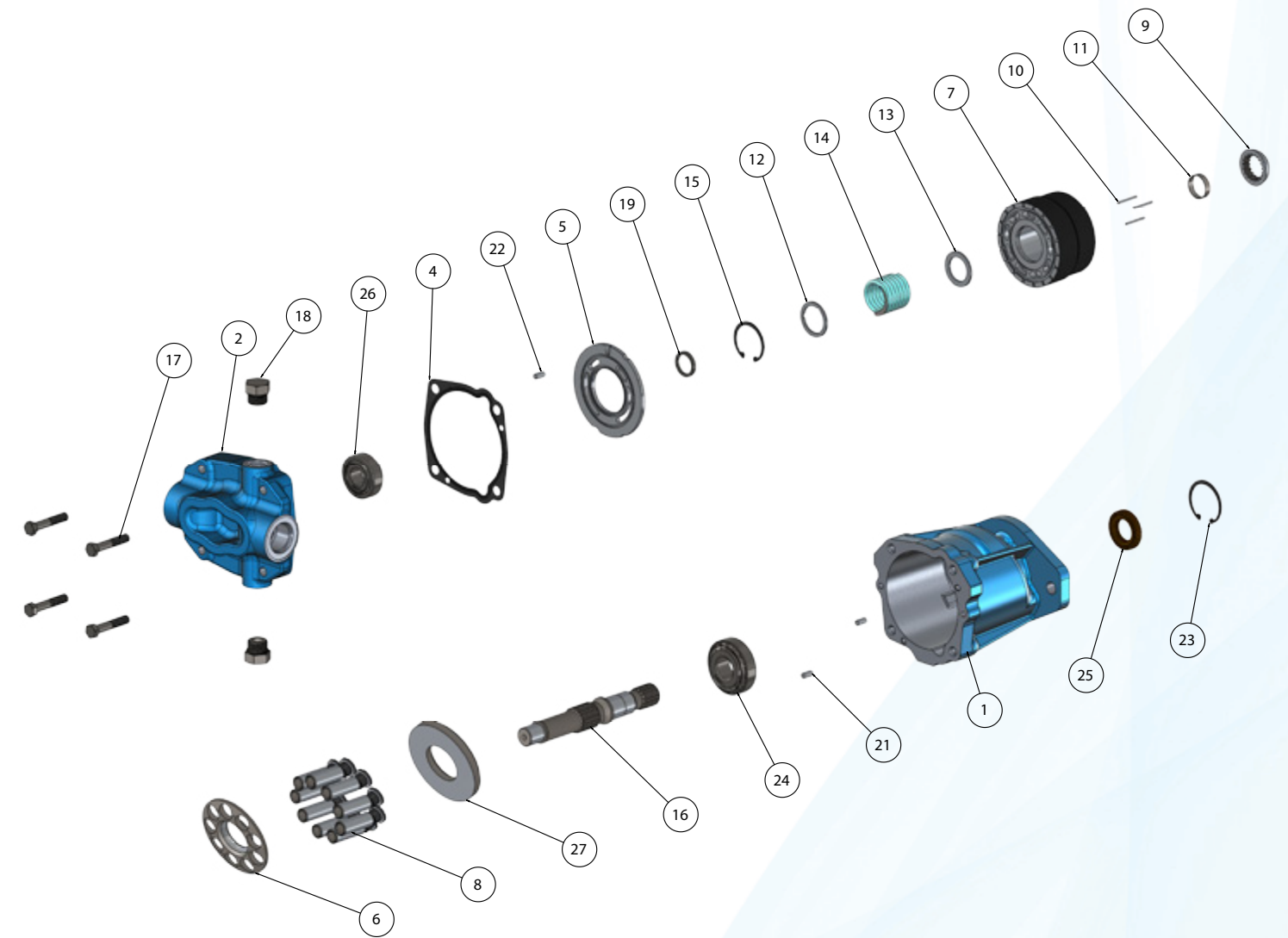

Model MFE15/19

ITEM	PART NUMBER		QTY	NOTE	DESCRIPTION
	Panagon	OEM			
1	PS84212	435304	1		Housing
1	PS7208	435276	1		Housing
2	PS84071	429727	1		Valve Block
2	PS84227	435918	1		Valve Block
3	PS1459	164432	1	C	Instruction Plate
4	PS2463	429731	1	A	Gasket
5	PS2461	435282	1		Control Plate
6	PS1301	402650	1	B	Shoe Plate
7	PS1866	432213	1	B	Cylinder Block
8	PS576444	923939	9	B	Piston/Shoe Subasm
9	PS1300	402580	1	B	Spherical Washer
10	PS1930	248810	3	B	Pin
11	PS1928	410050	1	B	Pin Retainer
12	PS1925	423368	1	B	Lift Limiter
13	PS1923	404932	1	B	Thrust Washer
14	PS2419	418271	1	B	Spring
15	PS7146	099907	1	B	Retaining Ring
16	See Table 1		1		Drive Shaft
17	PS776	167283	4		Hex Head Cap Screw
18	PS6042	181792	1		"O"-Ring Plug Subasm #10
19	PS1996	942401	1		Shaft Spacer
20	See Table 1		1	C	Key
21	PS80912	164056	2		Pin
22	PS10079	248910	1		Pin
23	PS1299	085560	1		Retaining Ring
24	PS1335	419627	1		Bearing
25	PS136810	471965	1	A	Shaft Seal
26	PS1834	473914	1		Bearing
27	PS3349	420905	1		Swashplate

- A Included in PS5800808 / 923979 MFE 19X Seal Kit
- B Included in PS3348 / 923933 Rotating Group Kit
- C Part not shown in exploded view

Table 1 - Shaft and Key				
Model Code	Panagon	OEM	Panagon	OEM
Model	Shaft		Key	
MFE15/19-2	PS2301	423421		
MFE15/19-6	PS3601	425424	--	--
MFE15/19-9	PS2293	429700		
MFE15/19-21	PS3602	581109	PS86486	582162
MFE15/19X-2	PS3603	423422		
MFE15/19X-5	PS3604	575313	--	--
MFE15/19X-9	PS3605	429734		
MFE15/19X-13	PS3606	426791	PS1616	5806
MFE15/19X-17	PS3607	434797	--	--

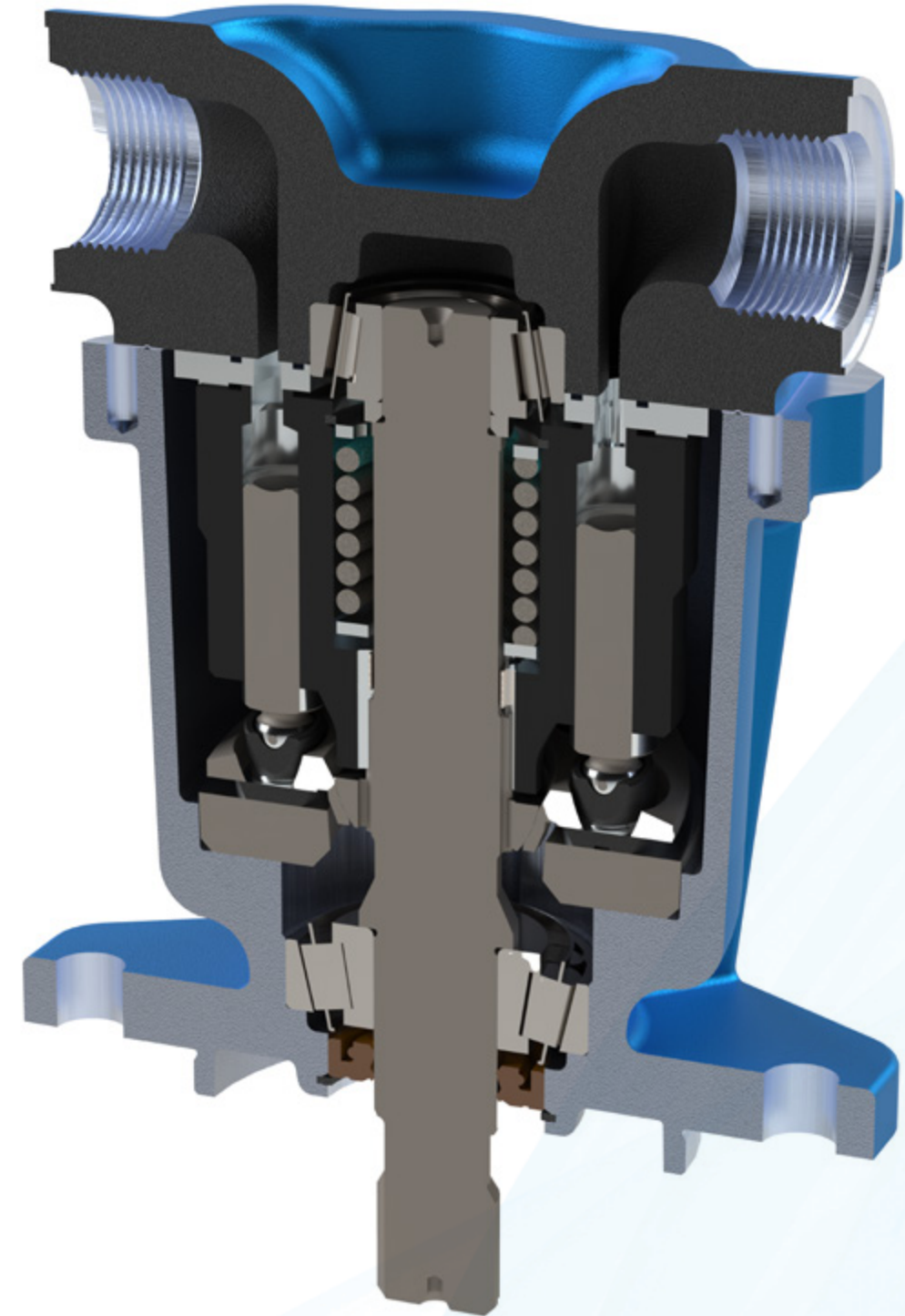

Model MFE15/19

M F E 1 9 (X) - * - 3 0

1 2 3 4 5

1 Model Series

MFE Motor, fixed displacement in-line piston unit, E-Series

2 Flow Rating @ 1800 RPM

15 15 USgpm
19 19 USgpm

3 Thru Shaft - Splined

2 15T - SAE B-B
5 13T - SAE B
9 13T - SAE B
13 Tapered key
17 15T - SAE B-B

4 Input Shaft

2 Splined, 15T - SAE B-B
6 Splined, 15T - SAE B-B
9 Splined, 13T - SAE B
21 Keyed, 0.875 dia - straight key

5 Design

Model MFE15/19

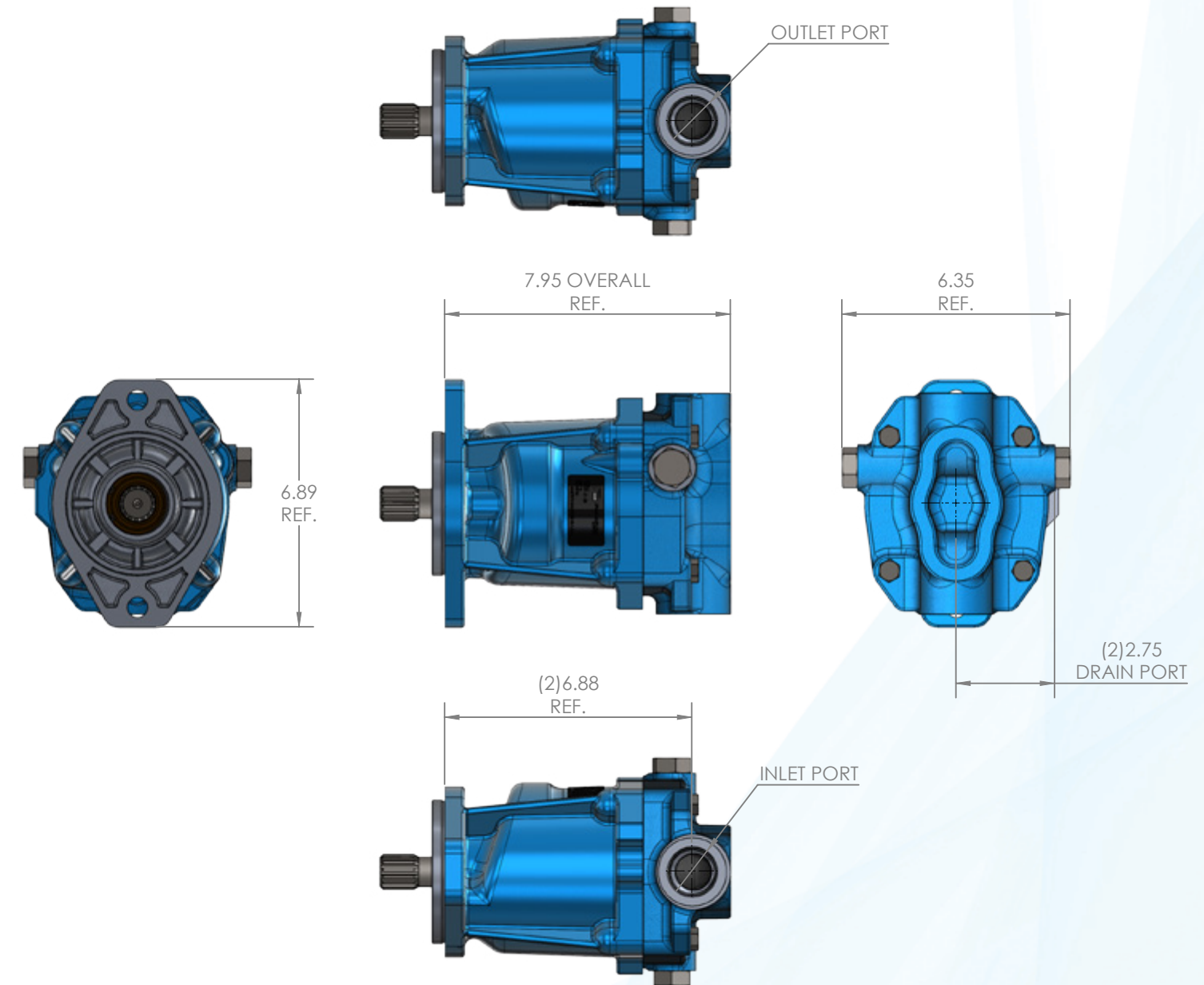



PROUDLY MANUFACTURED IN MACOMB, MICHIGAN

OEM Quality Hydraulic Pumps • OEM Quality Hydraulic Motors
OEM Quality Replacement Parts For: Vickers/Eaton, Rexroth and Caterpillar

51375 Regency Center Dr., Macomb, MI 48042 | Phone: 586-786-3920 | Fax: 586-786-7331
Email: sales@panagonsystems.com



WWW.PANAGONSYSTEMS.COM